



Model

56SS

Product Description

56SS (Pedestal Peeler, 25kg/56lb Heavy Duty)

Product Code

5P566 (56SSL low pedestal peeler 1ph)

5P568 (56SSL low pedestal peeler 3ph)

5P563 (56SSH high pedestal peeler 1ph)

5P564 (56SSH high pedestal peeler 3ph)



Standard Features

- The extremely efficient and robust 56SS Peeler is designed for regular high-volume use and enables up to 250kg of potatoes to be prepared every hour.
- Available in a choice of pedestal heights and with the option of an integrated filter basket.
- Featuring a large hopper opening with a robust lip, and simple to use wall mounted controls. To ensure operator safety the control unit also prevents automatic restart in the event of the power being cut.
- The motor wand water inlet both run exceptionally quiet, minimising the impact on the working environment.
- The 56SS is incredibly energy efficient, combined with faster peeling results in significant cost savings. The 1hp motor ensures that performance and reliability are maximised.
- Hygienic brushed stainless-steel finish. Water and waste drain away efficiently from the smooth cylinder base of the machines with the help of large paddles under the peeler plate, which are easy to remove and clean.
- Its solid cast aluminium peeler plate, stainless steel chute and hopper, tough door mechanism combine to offer a long maintenance-free service life
- Single phase machines come supplied with a 3-pin plug, the socket used should be away from any splash area and be accessible with the peeler installed. A dedicated supply to the socket is recommended and it should be protected by a C or D class circuit breaker rated 16amps.
- 3 phase machines should be connected to a 16amp isolator providing at least 3mm separation in all poles. The isolator should be fused at 10amp. The supply to the machine must also be protected by a 30ma RCD (residual circuit breaker)
- Marine voltages available, prices on request.
- 1-year parts and labour warranty

Standard Accessories

2 x Lifting Hook

Warranty

Covered by Metcalfe 1-year warranty and full after sales service

Optional Accessories

Item	Product Code
Guarded Discharge Chute for GU4	9P80

Item	Product Code
Waste Disposal Adaptor (WDA)	9P79

Drawing

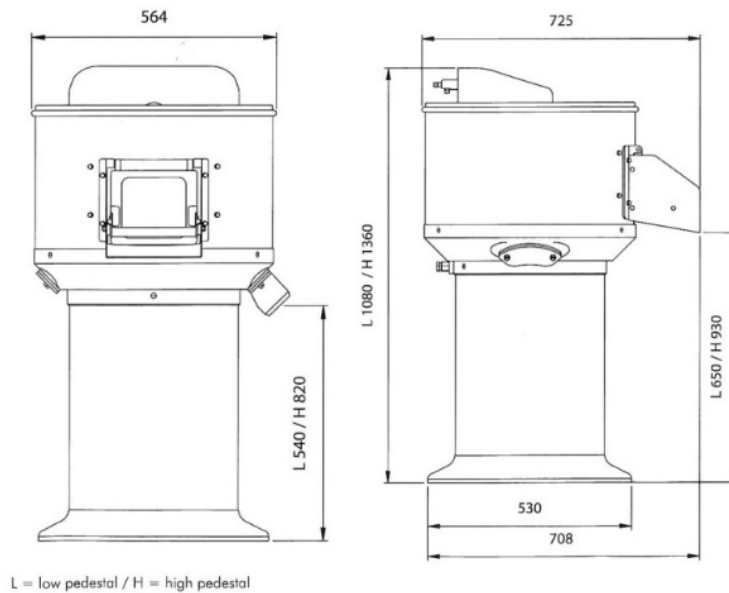

Specifications

Model	Product Code	Capacity (kg)	Discharge Height (mm)	Phase (Ø)	Motor (Volt)	Frequency (Hz)	AMP (A)	Power (kW/hp)
56SS (Low)	5P566	25	650	1	230	50	2.1	0.75 / 1.0
56SS (Low)	5P568	25	650	3	400	60	2.1	0.75 / 1.0
56SS (High)	5P563	25	930	1	230	50	2.1	0.75 / 1.0
56SS (High)	5P564	25	930	3	400	60	2.1	0.75 / 1.0

Dimensions | Shipping Information

Model	Overall Dimensions D x W x H (mm)	Net Weight (kg)	Packed Dimensions D x W x H (mm)	Packed Weight (Kg)	Volume (m3)
56SS (Low)	725 x 564 x 1080	64.5	790 x 640 x 1200	80	0.607
56SS (Low)	725 x 564 x 1080	64.5	790 x 640 x 1200	80	0.607
56SS (High)	725 x 564 x 1360	64.5	790 x 640 x 1480	80	0.748
56SS (High)	725 x 564 x 1360	64.5	790 x 640 x 1480	80	0.748

We reserve the right to alter the specification and technical details for this item at any time without prior notice.

1/2021

Metcalfe Catering Equipment Ltd

Haygarth Park
Blaenau Ffestiniog
Gwynedd, LL41 3PF

