

VISION

Orange 611 i, b

i – injection | b – boiler



UNIQUE BENEFITS



Vision Perfect Cooking

Make your diners great reason to keep returning to your place. With Retigo Vision combi ovens, you have the peace of mind that you will always achieve outstanding cooking results. The prepared foods have a perfect colour, are juicy, crispy and healthy with a minimal fat contain.



Vision Design

Simply keeps you cooking with ease and comfort. Experience an excellent combination of features, exceptional ergonomics and attractive appearance. All this with a focus on safety, hygiene and long time reliability.



Vision Controls

Gives you time to concentrate on cooking and things that really matter to you. The simplest controls on the market will save you time and enable you to quickly and easily make all the necessary settings. Panel response is perfect even with grease or gloved hands.



Smart Investment

Generates money on savings for you every day. In-buil heat exchanger, tripple glazed door glass, 50 mm thick thermoinsulation combined with low consumption automatic cleaning will ensure you great return on investment.

FEATURES & BENEFITS

Cooking

- **Hot air** 30 – 300 °C
- **Combination** 30 – 300 °C
- **Steaming** 30 – 130 °C
- **Bio steaming** 30 – 98 °C
- **Over night cooking** – Saves time and money.
- **Advanced steam generation system** – Two-step water preheating with in-built heat exchanger for perfect steam cooking results.
- **Crosswise racks** – Safer and comfortable GN handling. Better product visual control.
- **Regeneration/banqueting** – Cook, chill and regenerate to serve more diners in shorter times.
- **Low temperature cooking** – Benefit from less weight loss, better taste.
- **Automatic preheating/cooling** minimises the loading temperature drop. Start cooking with the desired temperature.
- **Sous-vide, Drying, Sterilization, Confit, Smoking** – Great way to make your menu special.*

Vision Controls

- **Touch panel** – Fast controls covered by high protective foil. Gives immediate reaction on commands, makes panel seamless and easy to clean.
- **Continuous cooking time option** - Saves your time during busy operations.
- **Automatic start** – The ability to schedule a delayed start.

Other equipment

- **Active Cleaning** – Low-cost automatic cleaning. No chef's time spent on cleaning any more.
- **Tripple glazed door glass** - Advanced energy savings and external glass that does not burn you.
- **Auto-reversing fan** – Excellent evenness to deliver high product color and texture uniformity.
- **Massive door handle** – Comfortable and safe handling with silver ion material contain for bacteria reduction.
- **AISI 304 stainless steel** – Exceptional quality with a special coating for a extended life time.
- **Hygienic cooking chamber with round inner corners** – Trouble free maintenance.
- **Run-off tray under the door** – No slipping on wet floor.
- **Two water inlets** – Saves a water treatment unit's capacity.
- **WSS (Water Saving System)** – Special drain system & in-built heat exchanger to save water related cost.
- **Removable GN holders** with 65 mm spacing

Conectivity

- **USB plug-in** – Transfer useful data easily to and from the combi oven.
- **VisionCombi software** – Program and pictogram management in your PC, HACCP data view.

Operation logs

- **HACCP records** – Easy and immediate analysis of critical cooking points.
- **Complete operating records**

Service

- **BCS** (Boiler Control System)** – Nothing stops you steam cooking with the in-built advance direct steam generation system.
- **SDS (Service Diagnostic System)** – Easy unit check up and trouble shooting.

Unit options

- Left door
- Safety door opening in two steps
- One point core probe
- Flap valve
- 99 programs with 9 steps
- Standard hand shower
- Retractable hand shower
- 7 Fan speeds + Fan Stop function
- Connection to the system for power consumption optimization

Optional accessories

- ST 1116 stand with 16 x GN 1/1
- ST 1116FP flat pack stand with 8 x GN 1/1
- ST 1116CS stand ST1116 with wheels
- ST 1116H stand with 16 x GN1/1, height 900 mm
- STAND with place for Holdomat
- STAND with place for BC411P or BC511P, C
- VISION VENT condensation hood
- GN ADAPTER for 2 x GN1/2 or 3 x GN1/3
- TRAY HOLDERS with spacing 85, 70 mm or GN 400/600
- OIL SPRAY GUN
- VISION SMOKER
- ACCESSORIES – Gastro containers, cleaning agents, water treatments

* unit options

** for boiler combi ovens only

TECHNICAL DATA

STACKING OPTIONS

Lower unit	Upper unit	
	611	611 ig
611	yes	yes
1011	yes	yes

OPTIONAL VOLTAGE

Model	611
1N~(2~)/220-240V/50-60Hz	yes
3~/220-240V/50-60Hz	yes
3~/400-480V/50-60Hz (without N)	yes

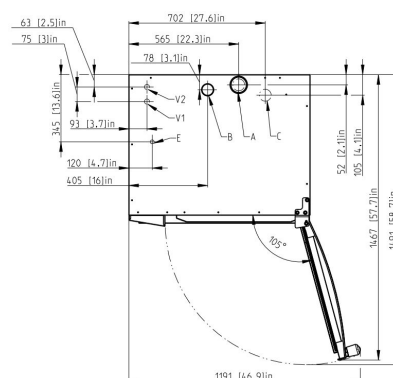
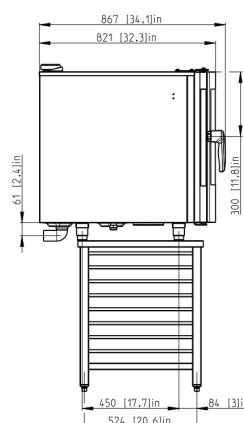
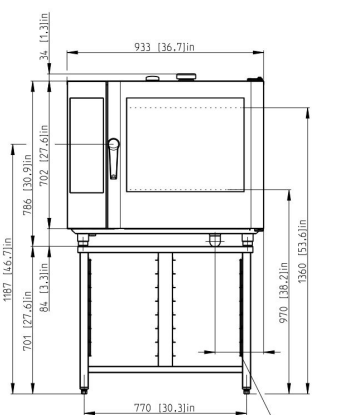

A	flap valve
B	chimney
C	waste
E	electricity
V1	untreated water
V2	treated water
Placed on ST 1116	

Model	O 611 i	O 611 b
Technical specification	2E0611IZ	2E0611BZ
Energy	Electricity	Electricity
Steam generator	Injection	Boiler
Capacity	7 x GN 1/1	7 x GN 1/1
Capacity (optional)	7 x 400/600	7 x 400/600
Capacity of meals	51 – 150	51 – 150
Spacing	65 mm	65 mm
Dimensions (w x h x d)	933 x 786 x 821 mm	933 x 786 x 821 mm
Weight	116 kg	122 kg
Total power	10,9 kW	10,9 kW
Heat power	10,3 kW	10,3 kW
Steam generator power	–	9 kW
Fuse	16 A	16 A
Voltage	3N~/400V/50-60 Hz	3N~/400V/50-60 Hz
Noise level	max. 70 dBA	max. 70 dBA
Water/Drain connection	G 3/4" / 50 mm	G 3/4" / 50 mm
Temperature	30 – 300 °C	30 – 300 °C